

TMdrive-MVG2

Product Application Guide

Medium Voltage Multilevel IGBT Drive

Up to 19,000 kVA , 3.3 kV, 4.16 kV to 11 kV











WWW.TMEIC.COM

The TMDrive-MVG2 is a medium-voltage, AC-fed drive designed for high-efficiency and power-friendly operation in a broad range of industrial applications.

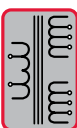
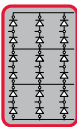
Bulletproof reliability, low harmonic distortion and high power factor operation are designed into the drive.



Design Feature	Customer Benefit
 <ul style="list-style-type: none"> Conservative design using 1700 V IGBTs 	<ul style="list-style-type: none"> Highly reliable operation, expected 15+ year drive MTBF
 <ul style="list-style-type: none"> Dry film type capacitors, not electrolytic type 	<ul style="list-style-type: none"> High reliability, 20 year+ capacitor life Frequent capacitor replacement or reforming periodically tasks are eliminated
 <ul style="list-style-type: none"> High energy efficiency of approximately 97% 	<ul style="list-style-type: none"> Considerable energy savings
 <ul style="list-style-type: none"> Diode rectifier ensures line-side power factor greater than 95% in the speed control range 	<ul style="list-style-type: none"> Capacitors not required for power factor correction
 <ul style="list-style-type: none"> Input isolation transformer included in drive package 	<ul style="list-style-type: none"> Better motor protection, elimination of common mode voltage Provides galvanic isolation of drive from power system Simplifies design and installation High BIL rating
 <ul style="list-style-type: none"> Multi-pulse converter rectifier and phase shifted transformer: <ul style="list-style-type: none"> 3.3 kV Class: 18 pulse 4.16 kV Class: 24 pulse 6.6 kV Class: 30 pulse 10 kV Class: 48 pulse 11 kV Class: 54 pulse 	<ul style="list-style-type: none"> No harmonic filter required to provide lower harmonic distortion levels than IEEE-519 guidelines
 <ul style="list-style-type: none"> Multiple level drive output waveform to the motor, 9 levels for 4.16kV class (0-peak) 	<ul style="list-style-type: none"> No derating of motor for voltage insulation or heating is required due to friendly output voltage waveform and near max sinusoidal current waveform
 <ul style="list-style-type: none"> Synchronous transfer to line option with no interruption to motor current 	<ul style="list-style-type: none"> Allows control of multiple motors with one drive No motor current or torque transients when the motor transitions to the AC line Bumpless, make-before-break transfer
 <ul style="list-style-type: none"> Direct drive voltage output up to 11kV 	<ul style="list-style-type: none"> No output transformer required, saving cost, mounting space, and energy
 <ul style="list-style-type: none"> Designed to keep running after utility supply-transient voltage dropouts – up to 300 msec. 	<ul style="list-style-type: none"> Uninterrupted service for critical loads

Designed for the most demanding applications

Oil & Gas

For Oil and Gas applications, the MVG2 family of variable frequency drives seamlessly integrates with the rest balance of process with a choice of 3/3.3 kV, 4.16 kV, 6/6.6 kV, 10kV or 11 kV options. The MVG2 can be applied to existing motors and cabling, making them an excellent option in modernization/retrofit applications, including:

- Oil pumps
- Gas compressors
- Extruders
- Fans
- Mixers



Power Generation

Traditional mechanical methods of controlling flow are inefficient and require considerable maintenance. In the Power Generation/Utilities industry, the MVG2 provides more reliable, accurate and energy-efficient control of flow while eliminating the maintenance associated with dampers, vanes or valves for:

- Induced and forced draft fans
- Primary and secondary air fans
- Boiler feed water pumps
- Condensate extraction pumps

Mining

Accurate torque control is a key in controlling large conveyors. The MVG2's flux vector algorithm provides the accuracy and response for constant torque applications. Mining applications include:

- Grinding mills
- Pumps
- Crushers
- Shredders
- Fans
- Conveyors



Industrial

Regardless of the torque profile, MVG2 drives are designed to meet motor control needs in a variety of industries:

- Steel
- Water & wastewater treatment
- Rubber & plastics
- Test stands
- Agriculture
- Paper & pulp
- Recreational/Entertainment

MV Drive Technology for medium voltage operation:

- Series connected inverter cell architecture uses 1700 V IGBT inverters for best reliability and high energy efficiency
- Diode bridge rectifiers yield high power factor operation
- Multi-winding phase shifting transformer produces low input power distortion
- Modular drawable power cell design minimizes the time required for any maintenance activities

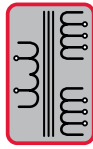

Input Transformer

The special input transformer has phase-shifted secondary windings to produce multi-pulse converter operation. This design exceeds the IEEE 519-2014 guidelines for input current distortion.

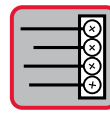

I/O Board

The I/O board supports encoder, 24 V dc I/O, 115 V ac inputs and analog I/O, standard. All I/O are terminated to a two-piece modular terminal block for ease of maintenance, located in right hand cabinet.

Main Power Input

Five voltage levels are available:

- 3-3.3 kV, 3-phase, 50/60 Hz
- 4.16 kV, 3-phase, 60 Hz
- 6-6.6 kV, 3-phase, 50/60 Hz
- 10 kV, 3-phase, 50/60 Hz
- 11 kV, 3-phase, 50/60 Hz

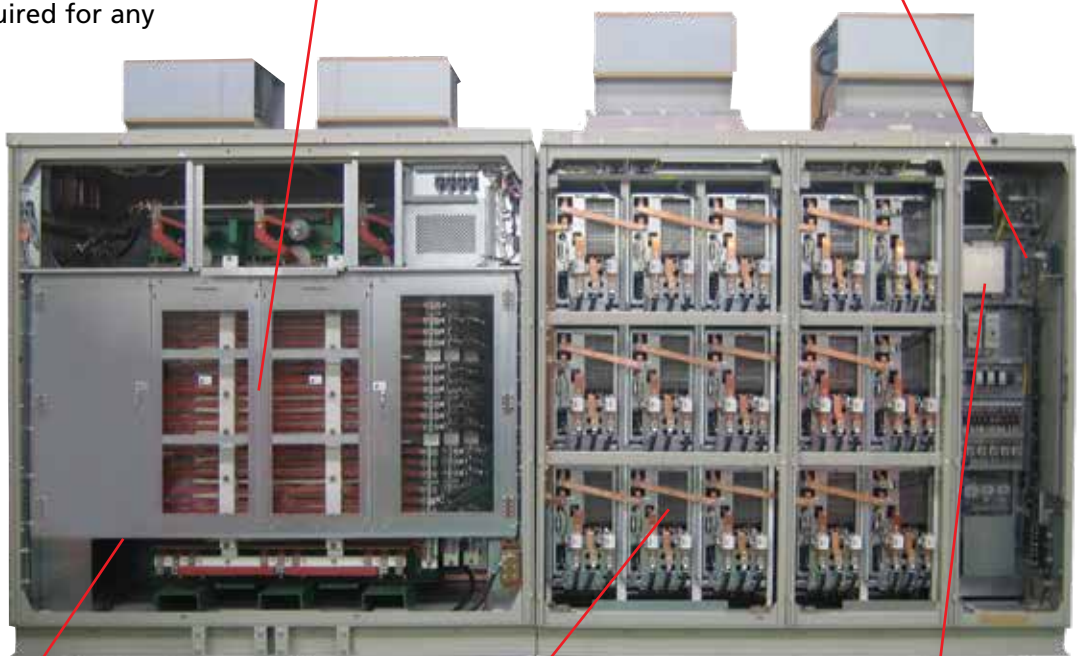

6.6 kV configuration shown (for illustration only)

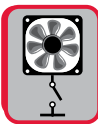

Air Cooling

Forced air cooling system with:

- Intake through cabinet doors
- Upward flow through inverter cells and transformer
- Exhaust at top of cabinet

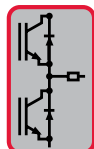

Cell Inverters

Example: Three banks of five (6.6kV), series connected inverter cells, each containing:

- Diode bridge rectifier
- IGBT PWM inverter
- Dry film type capacitor
- Input fuses
- Rack-in/out module for ease of maintenance

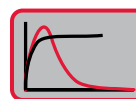

Control Functions

A single set of control boards feeds all inverter cells. The primary control board performs several functions:

- Speed and torque regulation
- Sequencing
- I/O mapping
- Diagnostic data gathering
- Provision for optional LAN interface

TMdrive-MVG2 Architecture

The TMdrive-MVG2 main circuit consists of an input transformer and single-phase PWM inverter cells. For 4 kV, four inverter cells are series connected to create an output with 9 (0-peak) output voltage levels.

TMdrive-MVG2 (4 kV class)

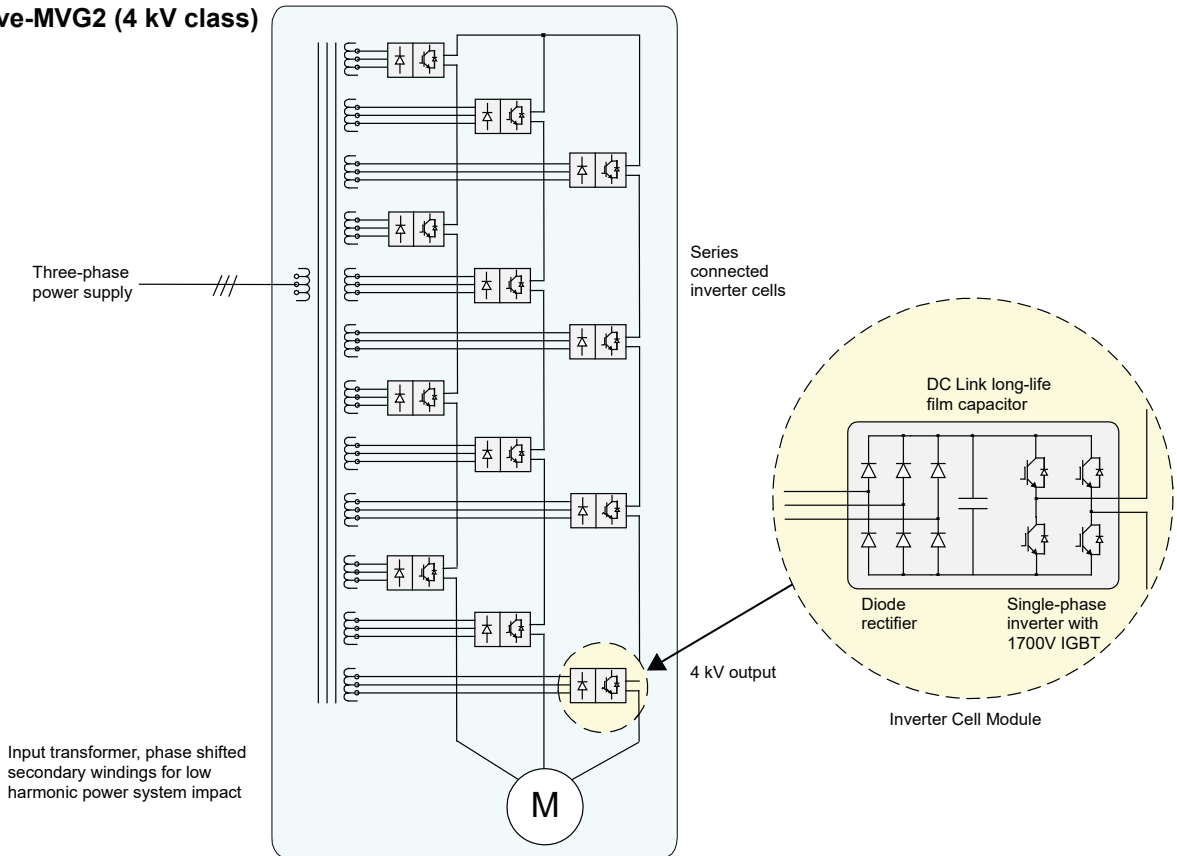

Rack in, Rack out

...in 30 minutes.

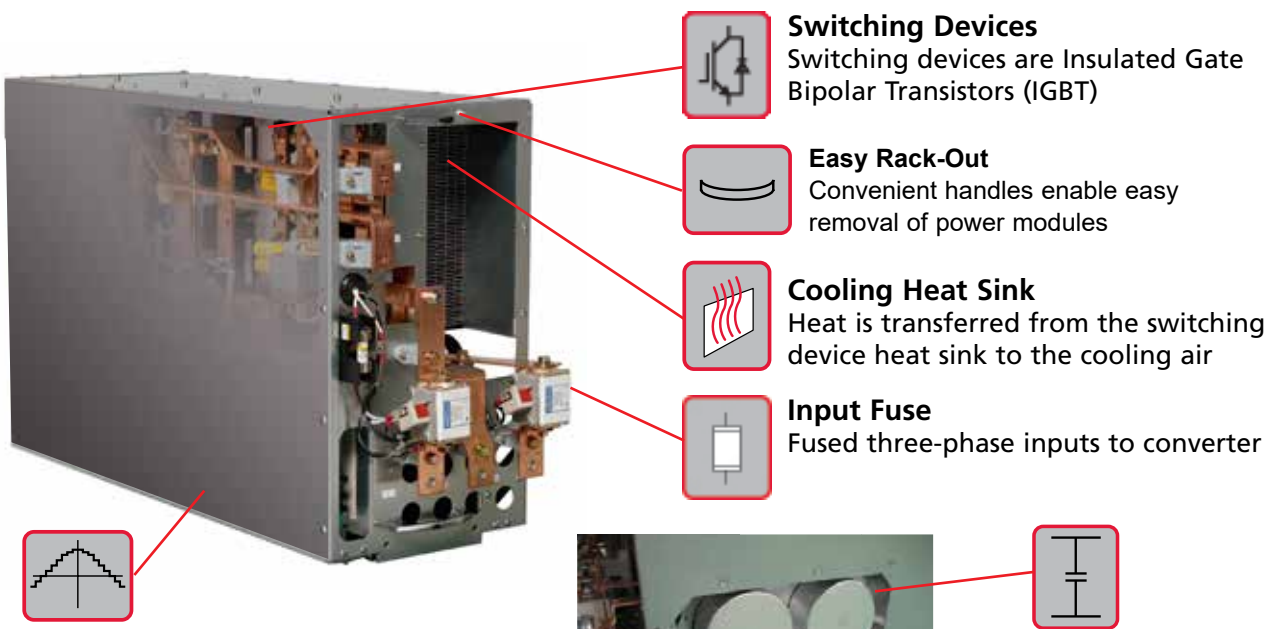

Switching Devices
Switching devices are Insulated Gate Bipolar Transistors (IGBT)

Easy Rack-Out
Convenient handles enable easy removal of power modules

Cooling Heat Sink
Heat is transferred from the switching device heat sink to the cooling air

Input Fuse
Fused three-phase inputs to converter

Control Board

- Board passes Pulse Width Modulated control signal to the gate drivers
- Gate driver circuit boards connect directly to IGBTs

DC Link Long Life Capacitors
No Electrolytic capacitor in main circuit is used. Replacement of deforming of capacitors is not required within product life.

Right side view

A Clean Wave Inverter

Using the multiple winding input transformer, the TMdrive-MVG2 has multi-pulse rectification and more than meets the requirements of IEEE-519 (2014). This reduces the harmonic current distortion on the power source and protects the other equipment in the plant. The harmonic current content measured in an actual load test is compared with IEEE-519 in the chart opposite.

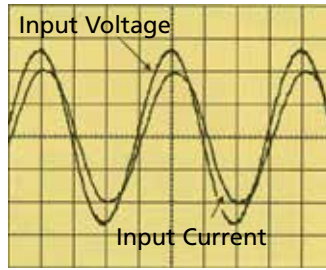

Typical line-side waveforms

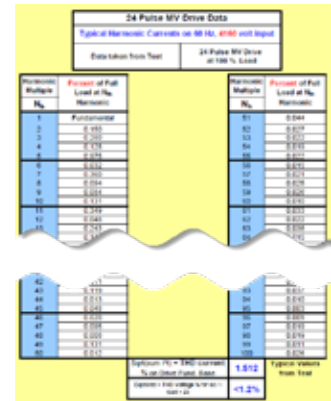

Typical Harmonic Contents of Input Current for 24-pulse converter

A Clean Output Wave

As a result of the multilevel PWM control, the output waveform is close to a sine wave, and the heat loss caused by harmonics is negligible. In addition, harmonic currents in the motor are minimized so there is very little torque ripple on the output shaft.

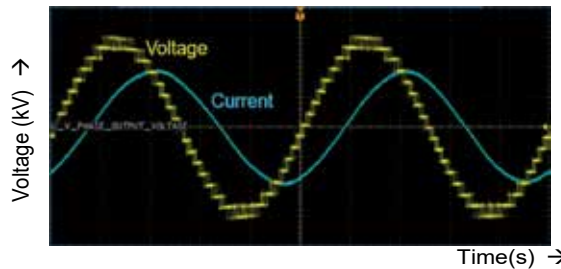

*Example of the actual test result of the standard 4.16 kV VFD

Current and Voltage Output Waveforms for 4.16 kV Drive

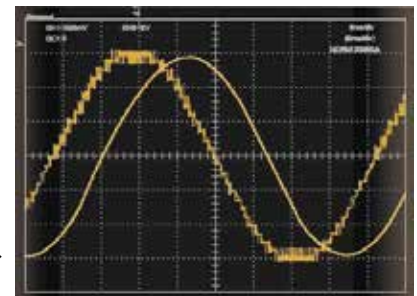

Current and Voltage Output Waveforms for 6 kV Drive

A Higher Efficiency than Conventional Drives

Actual factory load tests show the drive efficiency is approximately 97% (design value). This high efficiency is a result of:

- A smaller number of switching semiconductors by using 1700 V IGBTs
- Lower switching frequencies using multilevel PWM control reduce the switching loss of each IGBT
- Direct connection of MV motor without an output transformer

Example: 6.6 kV drive at 6,000 kVA and 50 Hz			
Current	100%	75%	50%
Efficiency	97.1%	97.2%	97.5%
Except for the consumption of control power and auxiliary power.			

A High Input Power Factor

Each inverter cell has a diode bridge rectifier. As a result, the input power factor is above 95% over the entire normal operating speed range, even when driving a multiple-pole induction motor of low power factor. With this high power factor, no power factor correction capacitor is required.

Power Factor in <i>Italic</i> , Expressed in % * = Interpolated Value		Percent of Top Speed vs % PF Lagging				
		20	40	60	80	100
Percent of Full Load	20	94.7%	95.5%	*95.6%	*95.7%	95.8%
	40		96.6%	96.7%	*96.4%	96.2%
	60			96.3%	96.4%	96.4%
	80				96.1%	96.8%
	100					97.1%
Examples of measured power factor						

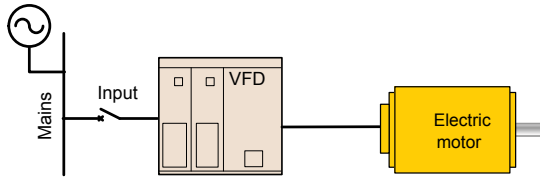
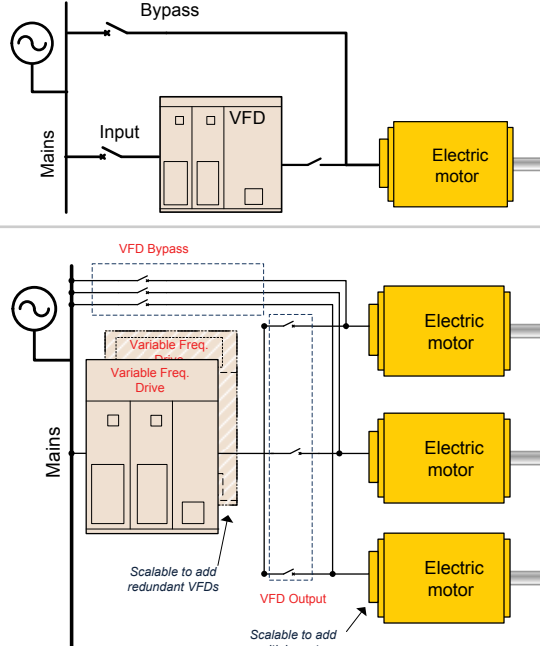
<p>Running duty</p>		<p>When appropriately rated, the MVG2 can be applied for continuous duty applications providing:</p> <ul style="list-style-type: none"> • Speed/process control • Constant/variable torque • Reduction in in-rush current
<p>Running and/or starting duty</p>		<p>TMEIC provides integrated packing of:</p> <ul style="list-style-type: none"> • Industrial Control Building • Output/Bypass Switchgear • Motor Control Centers • Control Systems <p>The MVG2 can be rated either for starting duty and/or running duty. With the appropriate switchgear lineup, the MVG2 control can automatically accelerate the connected motor to match the incoming utility voltage, frequency and phase. The load can then be bumplessly transferred to power source with no surges in torque or current. This allows for sequential starting of multiple motors with a single VFD. In a redundant arrangement, any motor can be started with either VFD, or can be configured as a hot-standby. Alternatively, the VFD can also capture the motor from the utility line and regain speed control.</p>

Maintenance

...Quick and Safe.



An optional lifter cart enables the operator to quickly rack-in/out the power modules.



Aluminum mesh air filters can be removed and cleaned while the VFD is running.

Frame sizes to fit your Application

4-4.16kV UL/CSA

Frame	Rated Output Current Amps		4.16 kV Output kVA	Approx. Motor HP @4.16kV	Approx. Motor Power kW @4.16 kV	Panel Width mm (inch)	Panel Height with channel base mm (inch)	Panel Depth mm (inch)	Approx. Weight kg (lbs)
	125%	110%							
800	-	551	3970	4450	3320	5370 (211)	2906 (114)	1402 (55)	9000 (19842)
1200	-	730	5260	5850	4365	5669 (223)	2906 (114)	1402 (55)	10000 (22046)
1400	-	833	6000	6400	4800	7050 (278)	3013 (119)	1800 (71)	15600 (34393)

3.0/3.3 kV

Frame	Rated Output Current Amps		3.0 kV Output kVA	3.3 kV Output kVA	Approx. Motor Power HP @ 3.3 kV *2	Approx. Motor Power kW @ 3.3 kV *2	Panel Width mm (inch)	Panel Height with channel base mm (inch)	Panel Depth mm (inch)	Approx. Weight kg (lbs)
	125%	110%								
100	35	-	180	200	200	160	2100 (83)	2690 (106)	900 (36)	2900 (6393)
	53	-	270	300	335	250				
	70	-	360	400	340	320				
	-	-	400	440	480	355				
200	105	-	540	600	600	450	2200 (87)	1000 (40)	3850 (8488)	
	140	-	720	800	880	650				
	-	-	800	880	960	710				
300	166	-	860	950	1000	750	2800 (111)	1000 (40)	4700 (10362)	
	192	-	1000	1100	1200	900				
	-	-	1080	1200	1300	970				
400	227	-	1180	1300	1350	1000	3100 (122)	1100 (44)	5800 (12787)	
	263	-	1360	1500	1700	1250				
	-	-	1500	1650	1800	1340				
600	315	-	1630	1800	1900	1400	4000 (158)	1100 (44)	6450 (14220)	
	350	-	1810	2000	2100	1600				
	385	-	2000	2200	2400	1800				
800	420	-	2200	2400	2700	2000	4600 (182)	1300 (52)	8300 (18298)	
	525	-	2720	3000	3400	2500				
1200	657	-	3410	3750	4100	3060	5400 (213)	1700 (67)	10000 (22046)	
1400	787	-	4090	4500	4800	3600	5700 (225)	3100 (122)	1800 (71)	12000 (26456)
Twin	CF 997	-	5180	5700	6100	4560	12800 (504)	2860 (113)	1300 (52)	later

Notes *2 Approximate capacity for 3.3 kV-based 4-pole induction motors
 CF There are two banks; consult factory for confirmation of dimensions and for weights
 Redundant cooling fans increase height

Frame sizes to fit your Application

6.0/6.6 kV

Frame	Rated Output Current Amps		6.0 kV Output kVA	6.6 kV Output kVA	Approx. Motor Power HP @ 6.6 kV*2	Approx Motor Power kW @ 6.6 kV*2	Panel Width mm (inch)	Panel Height with channel base mm (inch)	Panel Depth mm (inch)	Approx. Weight kg (lbs)
	125%	110%								
100	35	–	360	400	425	315	3200 (126)	2640 (104)	900 (36)	4320 (9524)
	53	–	540	600	610	450				
	70	–	720	800	875	650				
	–	–	800	880	960	710				
200	87	–	900	1000	1100	810	4000 (158)	2690 (106)		5550 (12236)
	105	–	1090	1200	1350	1000				
	122	–	1260	1400	1530	1130	4000 (158)	2690 (106)	1000 (40)	6250 (13779)
	140	–	1450	1600	1690	1250				
	–	–	1600	1760	1920	1420				
300	166	–	1720	1900	2160	1600	5000 (197)	2740 (108)	1000 (40)	7500 (16535)
	192	–	2000	2200	2430	1800				
	–	–	2160	2400	2620	1940				
400	227	–	2360	2600	3050	2250	5100 (201)	2760 (109)	1100 (44)	9100 (20062)
	262	–	2720	3000	3380	2500				
	–	–	3000	3300	3610	2670				
600	315	–	3270	3600	3780	2800	5900 (233)	2860 (113)	1200 (48)	10850 (23920)
	350	–	3630	4000	4260	3150				
	385	–	4000	4400	4800	3550				
800	420	–	4360	4800	5400	4000	5900 (233)	2860 (113)	1400 (56)	13050 (28770)
	473	–	4900	5400	6080	4500				
	525	–	5450	6000	6750	5000				
1200	569	–		6500	6975	5200	7100 (280)	2760 (109)	1800 (71)	17350 (38250)
	612	–		7000	7500	5600				
	656	–		7500	8040	6000				
	578	–	6000		6750@6.0kV	5000@6.0kV				
	626	–	6500		7560@6.0kV	5600@6.0kV				
	674	–	7000		8000@6.0kV	6000@6.0kV				
	730	–	7500		8780@6.0kV	6500@6.0kV				
1400	790	–	8200		8700@6.0kV	6500@6.0kV	10400 (410)	3125 (123)	1800 (71)	25000 (55115)
	867	–	9000		9865@6.0kV	7360@6.0kV				
	718	–		8200	8500	6300				
	790	–		9000	9650	7200	13000 (512)	3125 (123)	1800 (71)	30000 (66138)
Twin	CF 796	–	8270	9100	10800	8000	16200 (638)	2860 (113)	1400 (56)	later
	CF 898	–	9320	10260	11500	8500	16600 (654)			
	CF 997	–	10360	11400	13500	10000	16800 (662)			

Notes *2 Approximate capacity for 6.6kV-based 4-pole induction motors
 CF There are two banks; consult factory for confirmation of dimensions and for weights
 Redundant cooling fans increase height

Frame sizes to fit your Application

10/11 kV TMdrive-MVG2

Frame	Rated Current Output Amps		10 kV Output kVA	11 kV Output kVA	Approx. Motor Power HP @ 11kV*2	Approx Motor Power kW @ 11 kV*2	Panel Width mm (inch) @ 10 kV/11kV	Panel Height with channel base mm (inch)	Panel Depth mm (inch)	Approx. Weight kg (lbs) @ 10 kV/11kV
	125%	110%								
100	35	–	600	660	700	500	5300 (209) 5600 (221)	3060 (121)	1400 (56)	8280 (18210) 8620 (18960)
	53	–	900	990	1100	800				
	70	–	1200	1320	1400	1000				
	–	–	1330	1460	1420	1040				
200	87	–	1500	1650	1800	1350	6400 (252) 6800 (268)	3060 (121)	1400 (56)	9590 (21090) 10280 (22610)
	105	–	1800	2000	2200	1600				
	122	–	2100	2310	2500	1800				
	139	–	2400	2640	2760	2040				
	–	–	2660	2930	3210	2375				
300	162	–	2800	3080	3400	2500	6900 (272) 7500 (296)	3110 (122)	1500 (60)	12800 (28160) 13560 (29830)
	191	–	3300	3630	3780	2800				
	–	–	3630	4000	4400	3250				
400	226	–	3900	4290	4500	3500	7100 (280) 7700 (304)	3110 (123)	1500 (60)	14960 (32900) 15880 (34930)
	263	–	4500	5000	5200	3860				
	–	–	5000	5500	5940	4400				
600	315	–	5400	6000	6500	4900	11600 (457) 12200 (480)	3110 (123)	1500 (60)	23630 (51980) 24490 (53870)
	347	–	6000	6600	7200	5400				
	386	–	6680	7350	7800	5800				
800	420	–	7200	8000	8700	6500	11600 (457) 12200 (480)	3110 (123)	1500 (60)	27470 (60430) 28520 (62740)
	473	–	8100	9000	9800	7300				
	525	–	9000	10000	10900	8000				
1200	578	–	10000	–	10900@10kV	8000@10kV	13700 (540)	3107 (123)	1800 (71)	31050 (68453)
	636	–	11000	–	11500@10kV	8800@10kV				
	730	–	12600	–	13500@10kV	10000@10kV				
	578	–	–	11000	11500	8800				
	662	–	–	12600	13500	10000				
1400	790	–	13600	–	14500@10kV	10800@10kV	14500 (571)	3125 (123)	1800 (71)	39350 (86752)
	850	–	14700	–	15500@10kV	11500@10kV				
	718	–	–	13600	14500	10800				
	758	–	–	15000	16200	11500				
	850	–	–	16100	18100	13500	later	later	later	later
	867	–	15000	–	16440@10kV	12265@10kV	13900 (548) / 14500 (571)	3110 (123)	3860 (151)	63140 (138900) / 65240 (13520)
Twin	CF1024	–	17500	19500	21600	16000	13900 (548) 14500 (571)	3110 (123)	3860 (151)	63140 (138900) 65240 (143520)

Notes *2 Approximate capacity for 3.3 kV-based 4-pole induction motors
 CF There are two banks; consult factory for confirmation of dimensions and for weights
 Redundant cooling fans increase height

Specifications

Cabinet Minimum Maintenance Space

Output voltage	Frame	Front maint. space	Upper space	Rear maint. space	Maint. type
3/3.3 kV class	100	1600 mm (63 in)	700 mm (28 in)	– (Plate mounting screw sticks out 20 mm on back)	Front
	200	1600 mm (63 in)			
	300	1700 mm (67 in)			
	400	1700 mm (67 in)			
	600	1700 mm (67 in)			Front/ rear
	800	1900 mm (75 in)			
	1200	1900 mm (75 in)			
	1400	2000 mm (79 in)			
4.16 kV class	600	1,700 mm (67 in)	700 mm (27 in)	– (Plate mounting screw sticks out 20 mm on back)	Front
	800	1,900 mm (75 in)			
	1200	1,900 mm (75 in)			Front/ Rear
	1400	2,000 mm (79 in)			
6/6.6 kV class	100	1600 mm (63 in)	700 mm (28 in)	– (Plate mounting screw sticks out 20 mm on back)	Front
	200	1600 mm (63 in)			
	300	1700 mm (67 in)			
	400	1700 mm (67 in)			
	600	1700 mm (67 in)			Front/ Rear
	800	1900 mm (75 in)			
	1200	1900 mm (75 in)			
	1400	2000 mm (79 in)			
10/11 kV class	100	1800 mm (71 in)	900 mm (36 in)	600 mm (24 in)	Front/ Rear
	200	1800 mm (71 in)			
	300	1900 mm (75 in)			
	400	1900 mm (75 in)			
	600	2000 mm (79 in)			600 mm (24 in)
	800	2000 mm (79 in)			
	1200	2000 mm (79 in)			
	1400	2000 mm (79 in)			

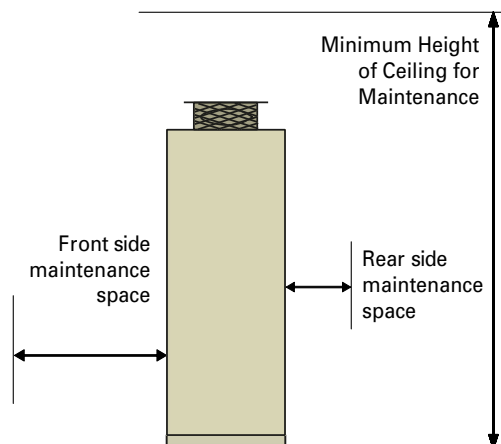

Notes

- $$kVA_{Inverter} = \frac{Power_{Mtr Shaft}}{(Mtr PF \times Mtr Eff)}$$

$$I_{Phase} = \frac{kVA_{Inverter}}{\sqrt{Mtr Line to Line}} \times (1000) / (1.732) \times$$
 - Mtr PF = 0.85, Mtr Eff = 0.95, ambient temperature is 32°F–104°F (0°C–40°C).
 - Ratings based on a variable torque load (industrial fans and pumps).
 - Altitude above sea level is 0–3300 ft (0–1000 m).
- Derating factors:
 - 1.8% per °C over 40°C, must be 40°C daily average and 35°C average annual average or more derating is required.
 - Output current decreases 1% per 100m above 1000m
 - Output voltage maximum decreases with altitude over 2000 m to 88% of normal at 3000 m.
- An optional bypass circuit can be separately mounted.
- Dimensions to top of cooling fans are for the non redundant type fans. Redundant cooling fans are available as an option; overall height increases.
- No rear access is required except for 10/11 kV class drives and Frame 6, 7, 3.3, 4.16 kV, and 6.6 kV class drives.
- Incoming power cabling and motor cabling are bottom entry; top entry is an option, may add length.
- Air is pulled in through the filters in the cabinet doors and vented out the top.
- Available options include motor cooling fans and space heater control, cabinet space heater, bypass power/controls and dv/dt filter, HV input, sync motor control, smooth transfer to and from utility.
- For conservative sizing of cooling equipment, use heat rejection of 3 kW/100 HP of actual output power. Typical kW/100 HP is around 2.4 kW at 97% drive efficiency
- The panels are fixed to the channel bases and shipped.
- Contact the TMEIC Application Center for further details.

Specifications

Control I/O	
Control Area	Specifications
Analog Inputs	(2) ± 10 V or 4-20 mA, configurable, differential
Analog Outputs	(4) ± 10 V, 8-bit, configurable, 10mA max
Digital Inputs	(2) 24–110 V dc or 48–120 V ac; (6) 24 V dc, configurable
Digital Outputs	(6) 24 V dc open collector 50 mA
Speed Feedback Encoder Input	High-resolution tach, 10 kHz, 5 or 15 V dc diff. input, A Quad B, with marker
LAN Interface Options	Profibus-DP, Ethernet IP, Ethernet EGD, DeviceNet™, TOSLINE®-S20, or Modbus RTU
Motor Temp. Sensor	High-resolution torque motor temp. feedback: 100 Ohm platinum RTD (uses analog input with signal conditioner)

Display and Diagnostics	
	Specifications
PC Configuration	Control System Drive Navigator for configuration, local and remote monitoring, animated block diagrams, dynamic live and capture buffer based trending, fault diagnostics, commissioning wizard, and regulator tune-up wizards. Ethernet 10 Mbps point to point or multi-drop, each drive has its own IP address
Keypad and Display	Backlit LCD, animated displays <ul style="list-style-type: none"> • Parameter editing • Four configurable bar graphs • Drive control • Optional multi language display
Instrumentation Interface	Two analog outputs dedicated to motor current feedback, plus five analog outputs that can be mapped to variables for external data logging and analysis

Additional specifications

Power System Input and Harmonic Data

- Voltage: up to 11 kV, 3-phase, +10%/–10%
- 13.8 kV input available for select frames
- Tolerates power dips up to 25% without tripping, complete power loss ride through of 300 msec
- 125% Overload (OL) for 60 seconds; other OL ratings available
- Frequency: 50 Hz or 60 Hz, $\pm 5\%$, 60 Hz for 4.16 kV only
- Power factor (PF): 0.95 lag
- True PF: greater than 0.95 lag over 40–100% speed range
- Exceeds the IEEE 519 standard for current harmonics, without filters
- Bottom cable entry, top entry as option (may require extra width)

Converter Type

- AC-fed multi-pulse diode using phase shifted transformer
- 18 pulse for 2.4 and 3.3 kV, 24 pulse for 4.16 kV, 30 pulse for 6 kV, 48 pulse for 10kV, and 54 pulse for 11 kV

Transformer

- Dry type aluminum or copper wound, 140°C rise
- Air-cooled type
- Multiple phase shifted LV windings

Inverter

- Multilevel inverter cells for smooth output to motor:
 - three in series for 2.4 and 3.3 kV inverter
 - four in series for 4.16 kV inverter
 - five in series for 6.6 kV inverter
 - eight in series for 10 kV inverter
 - nine in series for 11 kV inverter
- Up to 120 Hz, for 6/6.6 kV and below
- For 10/11 kV, maximum frequency 72 Hz
- Multilevel output for motor-friendly waveform

Applicable Standards

- IEC61800-4, JIS, JEC, JEM, IEEE519

Operating Environment and Needs

- Temperature: 0° to +40°C
- Humidity: 85% maximum, noncondensing
- Altitude: Up to 1000 m (3300 ft) above sea level:
- Fan: 380/400/440 Vac, 3 phase, 50 Hz or 60 Hz
- Control Power (by user): 120 Vac, 3 phase, 60 Hz or 220 Vac, 3 phase, 50 Hz

Cooling

- Air-cooled with fans on top

Typical Noise

- Approx. 79 dB(A) @ 50 Hz, at 3.1 ft (1 m) from enclosure
- Approx. 83 dB(A) @ 60 Hz, at 3.1 ft (1 m) from enclosure

Control

- Nonvolatile memory for parameters and fault data
- Vector control with or without speed feedback, or Volts/Hz
- Designed to keep running after utility supply transient voltage dropouts of 300 ms
- Synchronous transfer to line option
- Synchronous motor control (option)

Vector Control Accuracy and Response

- Maximum speed regulator response: 20 rad/sec
- Speed regulation without speed sensor $\pm 0.5\%$
- Maximum torque current response: 500 rad/sec
- Torque accuracy: $\pm 3\%$ with temp sensor, $\pm 10\%$ without
- Speed control range, 5-100%

Major Protective Functions

- Inverter overcurrent, overvoltage
- Low or loss of system voltage
- Motor ground fault
- Motor overload
- Cooling fan abnormal
- Over-temperature
- CPU error

Enclosure

- IP30 except for fan openings (IEC 60529), NEMA1 gasketed equivalent
- Color: Munsell 5Y7/1

Empower Your Crew: Local and Remote Control



TMdrive Navigator

The MVG2 keypad, coupled with the Windows® based TMdrive Navigator brings productivity to your commissioning and maintenance activities.

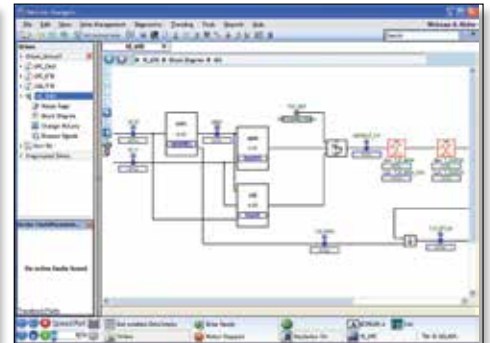
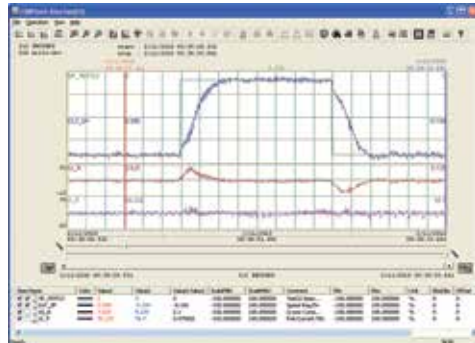

The Navigator tool helps maintain TMEIC drives in the field. Any user can easily access current drive expertise & know-how.

Compatible with Windows-based OS.

High speed data is automatically captured and saved in the event of a drive fault. Users can capture high speed data based on their own trigger conditions or perform high resolution real-time trending.

Live block diagrams provide a real-time graphical view of drive functions. Functions can be configured directly from the graphical view.

Product documentation is integrated into tool. Users can capture their own notes to benefit future troubleshooting.



Operator Keypad (Standard)

High Function Display

- LCD backlight gives great visibility & long life
- Bar graphs, icons, menus, and digital values combine to provide concise status information, often eliminating the need for traditional analog meters

RJ-45 Ethernet port is used for the TMdrive Navigator

Instrumentation Interface

- Two analog outputs are dedicated to motor current feedback
- Five analog outputs are mapped to variables for external data logging and analysis



Easy to understand navigation buttons allow quick access to information without resorting to a PC based tool

Local indicator of DC Bus status advises when it is safe to open the VFD cabinet.

Interlock button disables the drive

Switch to local mode to operate the equipment from the keypad



Multilingual Keypad (Optional)

An optional touch screen display is available with 9 languages built in. The graphic display is easy to read and understand and contains all of the same functions as the standard keypad.



At TMEIC, we provide highly-reliable automation systems. Sometimes even the best systems can experience faults. For events we can't foresee, TMEIC offers remote diagnostics with RCM[®] - protection for your investment, by reducing downtime, lowering repair costs and providing peace of mind.

Remote drive connectivity requires an internet connection between your plant and TMEIC for retrieval of fault logs and files for diagnosing drive problems. The RCM[®] enables seamless integration between your drives and our support engineers.

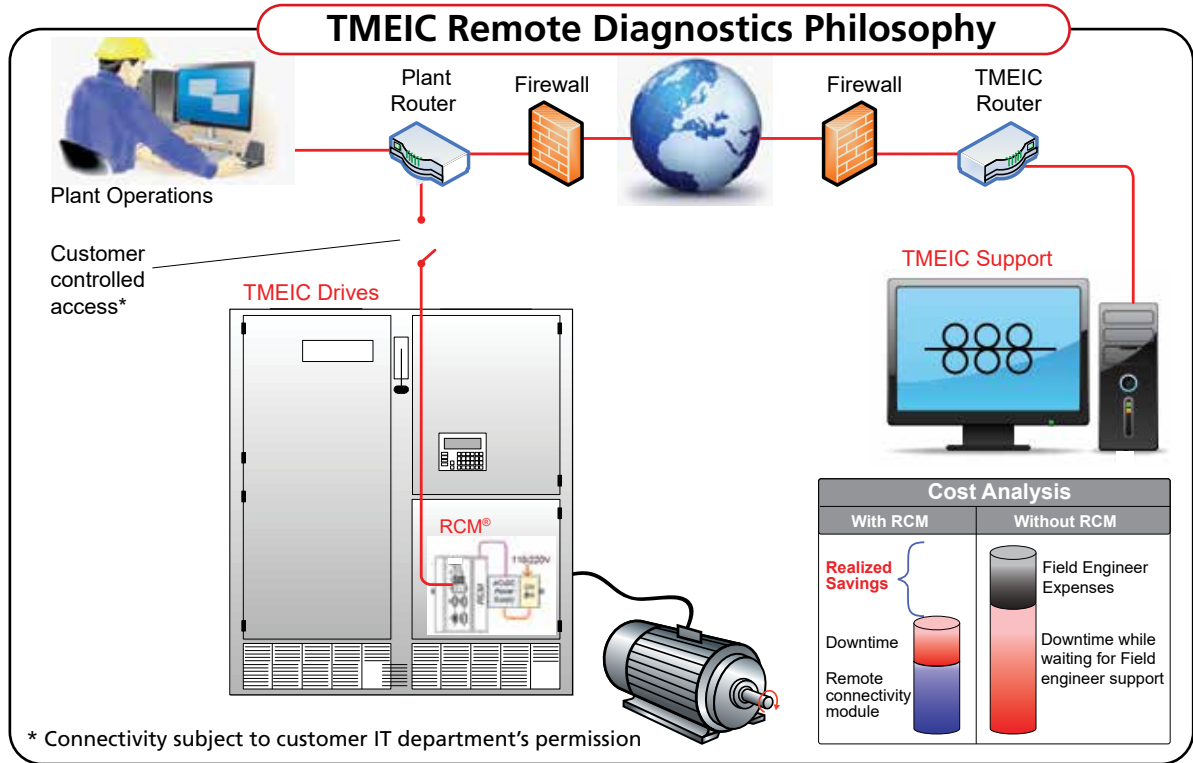

Features

- Reduced downtime and Mean-Time-to-Repair
- Secured connection*
- Auto Upload via TMdrive-Navigator
- Industrial computer
- Multiple ethernet/serial ports

Benefits

Quick support saves thousands of \$ in lost production TMEIC engineers can quickly connect* to the drive and diagnose many issues in a matter of minutes.

Customer-controlled access
All remote activity is conducted with permission of the customer. Drive start/stop is not permitted remotely.

Proprietary Traceback Upload
TMdrive-Navigator's auto upload capability can save traceback data to the RCM exclusively. This enables TMEIC engineers to analyze the issue resulting in the fault and provide a more coherent solution.

Ruggedized computer for the most demanding applications
Fan-less computer withstands high vibration and temperature ranges in a small DIN-rail mounted footprint

Flexible connectivity
The module can be connected to two separate LAN's along with a host of serial-talking/USB devices.

Who do you call if you have issues?

- 24/7/365 Tech Support to help you when you most need it.
- TMEIC Maintains history of your equipment and application to quickly resolve any issues you may have.

Whether the equipment is up and running or experiencing downtime, live help from TMEIC is a phone call away. With bases in North America and around the world, regional TMEIC companies and TMEIC motor service shops provide reliable support whenever needed.

We know you operate 24 hours a day, 365 days a year. SO DO WE.

- Staffed by trained service engineers
- Supported by factory design engineers



For Service Call
877-280-1835

INTERNATIONAL
+1 540-283-2010

www.tmeic.com/customer-support



Delivering customer success every project, every time.

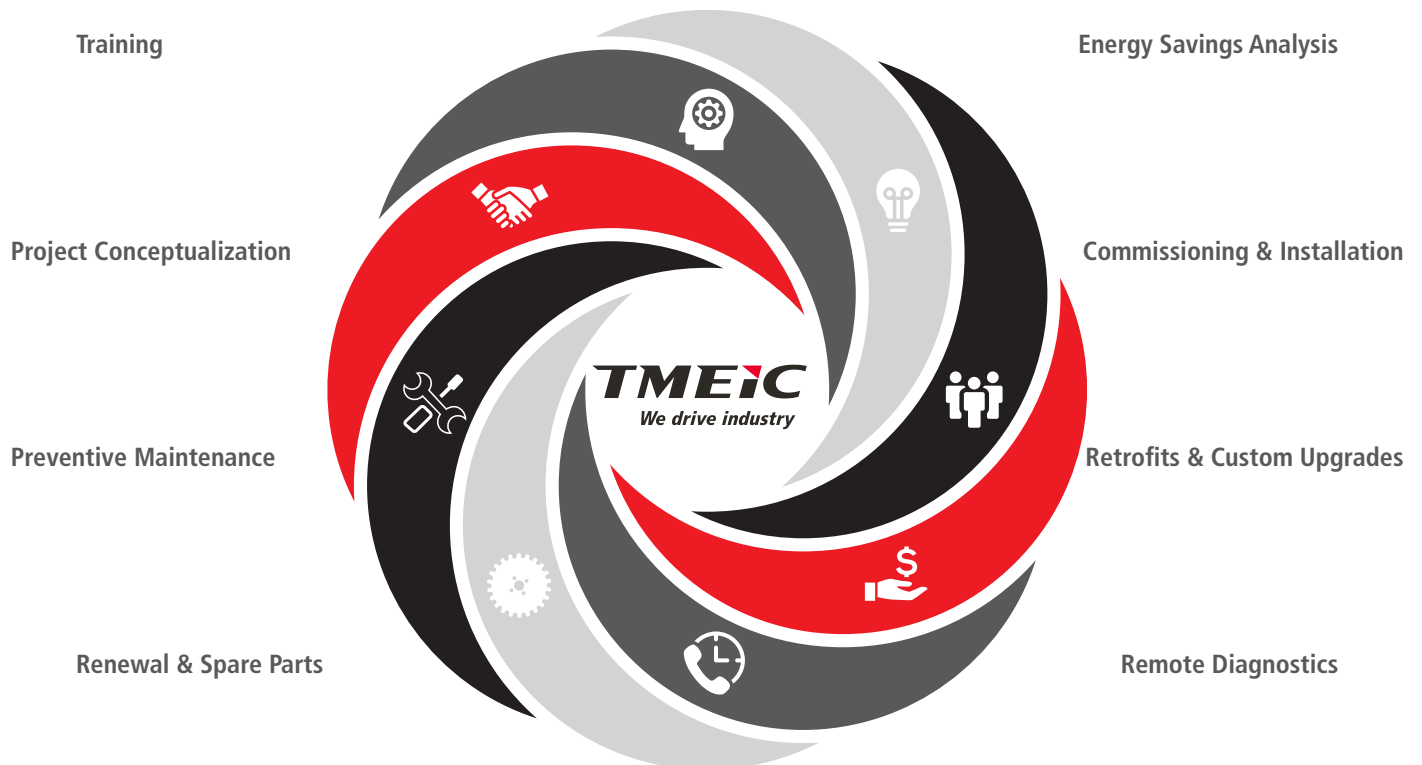



TMEIC AC Drives Offer Complete Coverage

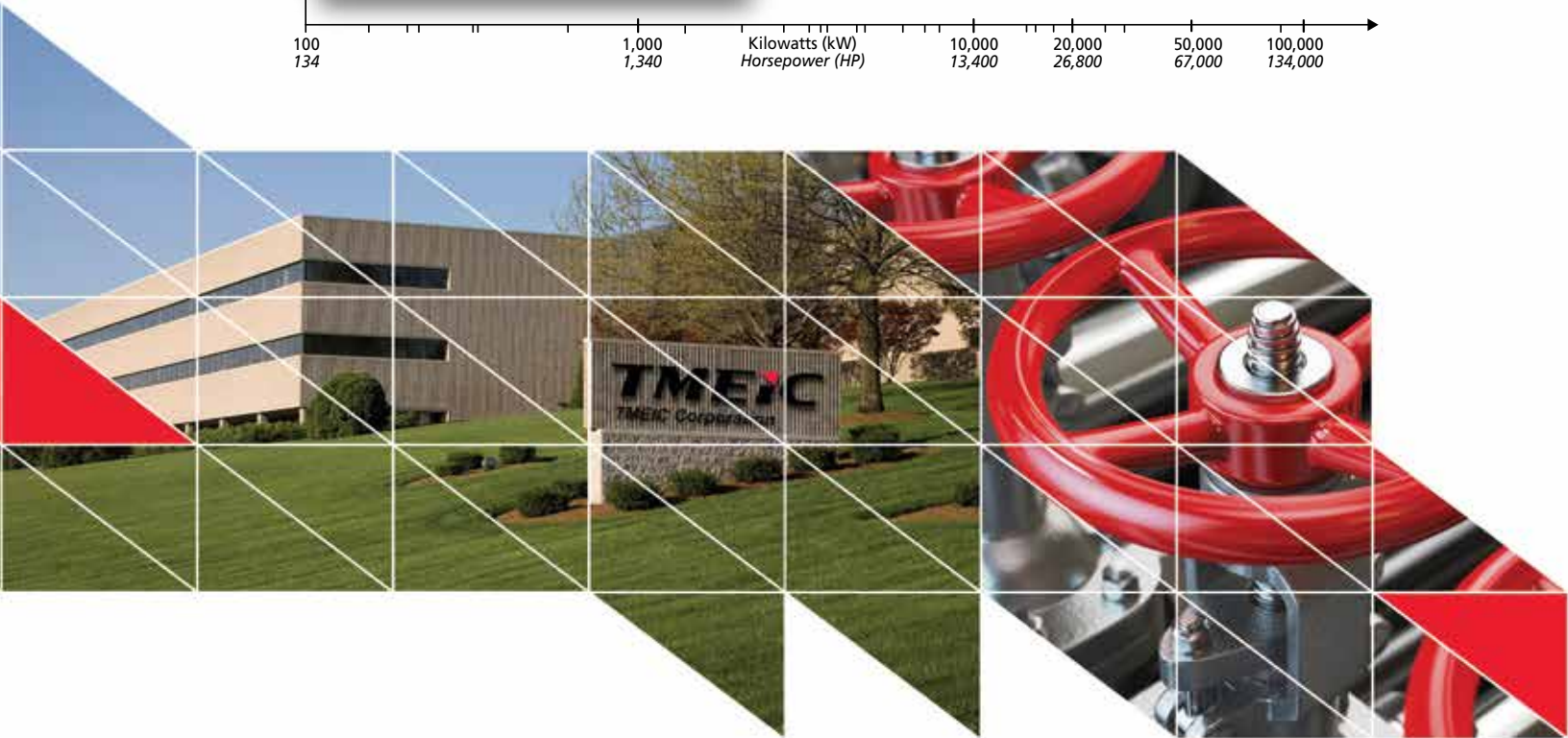
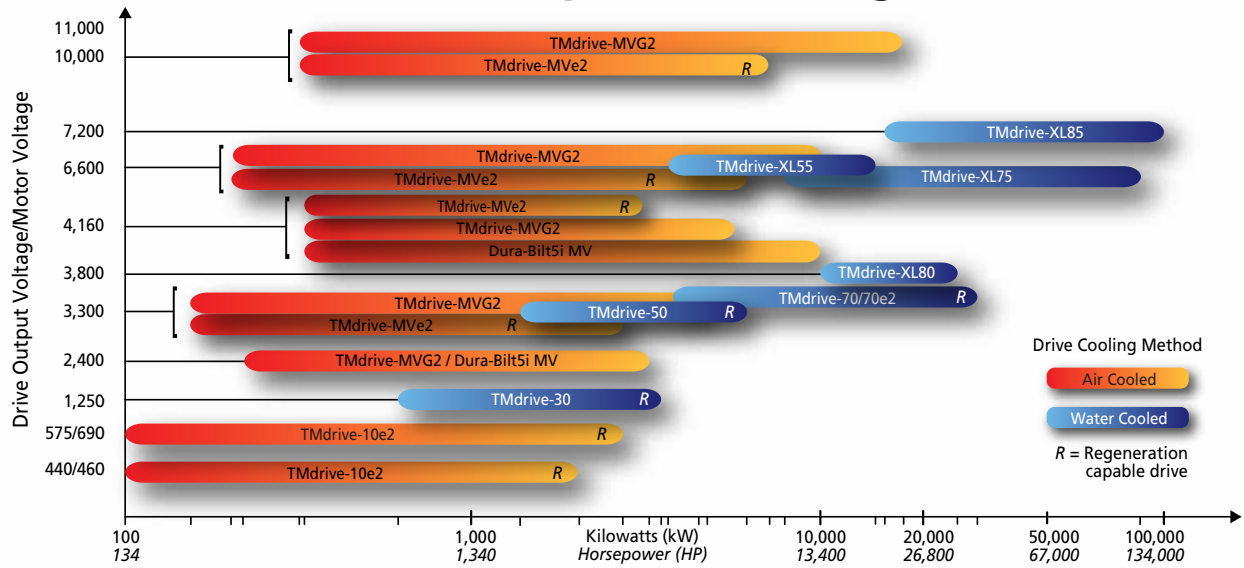

TMEIC Corporation | Roanoke, Virginia, USA | GI@TMEIC.COM | WWW.TMEIC.COM

All specifications in this document are subject to change without notice. This brochure is provided free of charge and without obligation to the reader or to TMEIC. TMEIC does not accept, nor imply, the acceptance of any liability with regard to the use of the information provided. TMEIC provides the information included herein as is and without warranty of any kind, express or implied, including, but not limited to, any implied statutory warranty of merchantability or fitness for particular purposes. The information is provided solely as a general reference to the potential benefits that may be attributable to the technology discussed. Individual results may vary. Independent analysis and testing of each application is required to determine the results and benefits to be achieved from the technology discussed.

TMdrive is a trademark of TMEIC Corporation.
© 2021 TMEIC Corporation. All Rights Reserved.

D-0008
Revised Jan. 2021